

**MUST COMPLY WITH SB407
WATER-CONSERVING PLUMBING
FIXTURES AT FINAL INSPECTION**



City of Porterville Building Division

291 N Main Street, Porterville, CA 93257 (559) 782-7480

**10-YEAR SEALED BATTERY
SMOKE AND CO DETECTORS
REQUIRED, PER CRC**

STANDARD PATIO PLAN

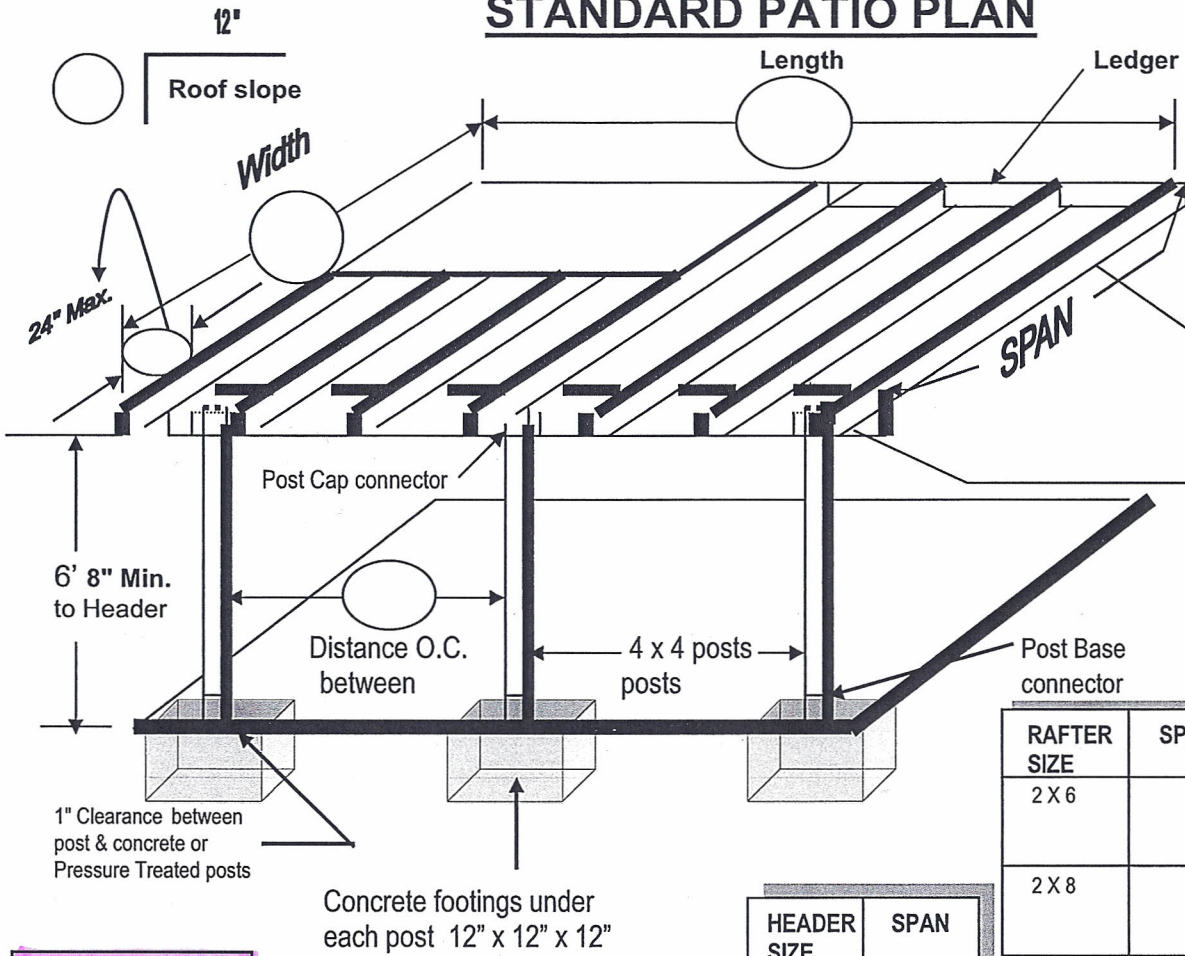

Electrical? YES or NO
Describe: _____

Roof type

Sheathing
 7/16" OSB
 1/2" Plywood *

Rafter size
____ " X ____ "
____ " O.C.

Header size
____ " X ____ "

Maximum Height

RAFTER SIZE	SPACING	SPAN ALLOWED
2 X 6	12"	14' - 4"
	16"	12' - 5"
	24"	10' - 2"
2 X 8	12"	18' - 2"
	16"	15' - 9"
	24"	12' - 10"
2 X 10	12"	22' - 3"
	16"	19' - 3"
	24"	15' - 8"
2 X 12	12"	25' - 9"
	16"	22' - 4"
	24"	18' - 3"

HEADER SIZE	SPAN
4 X 6	6 FT.
4 X 8	8 FT.
4 X 10	10 FT.
4 X 12	12 FT.

Schedule the footing inspection before pouring the concrete

Approved methods of attachments Check one

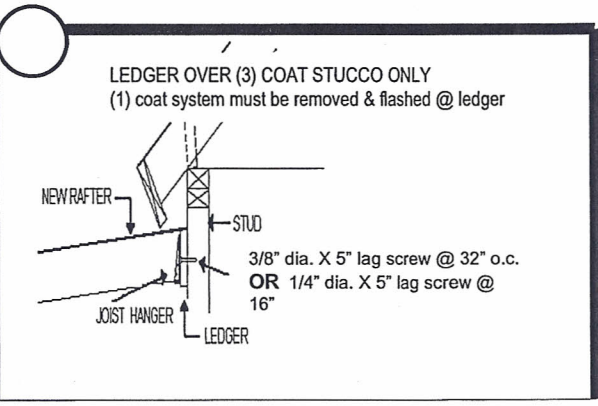
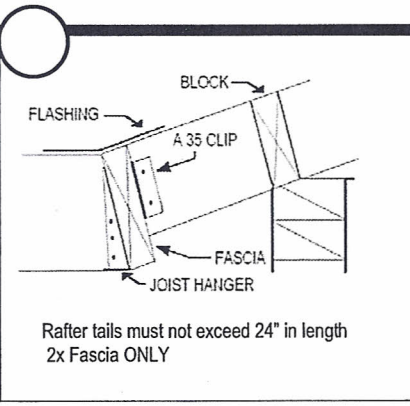
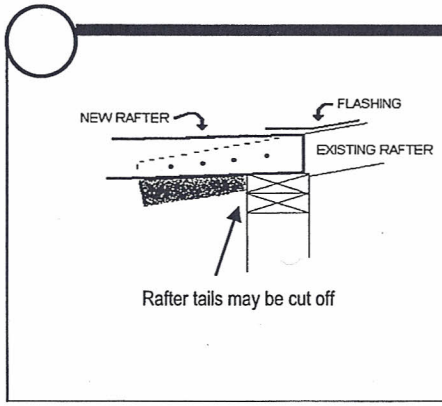

This design not approved to be enclosed.
* Exposed plywood shall be CCX or better.